

445nm 4W Fiber Coupled Diode Laser

K445H03FN-4.000WN0N-10522

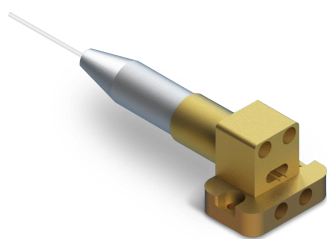

Features:

- ◆ 445nm wavelength
- ◆ 4W output power
- ◆ 105 μ m fiber core diameter
- ◆ 0.22 NA

Applications:

- ◆ illuminating
- ◆ 3D Printing
- ◆ Medical use

BWT, founded in 2003, is committed to the mission of "let the dream drive the light", the vision of becoming the "Global leader in laser solutions", and the value of "Outstanding innovation", providing diode laser, fiber laser, ultra-fast laser products and solutions to global customers.

BWT pursues continuous innovation and insists on autonomous and controllable advanced process and technology. With Beijing headquarters as the core, BWT has successively established production and R&D centers in Jiangsu, and Shenzhen, and Invested in the construction of an automated and intelligent production base in Tianjin. To build a high level of technical strength and product quality, BWT set up a German subsidiary in 2020, and taking a solid step for the internationalization of R&D, production and technological innovation.

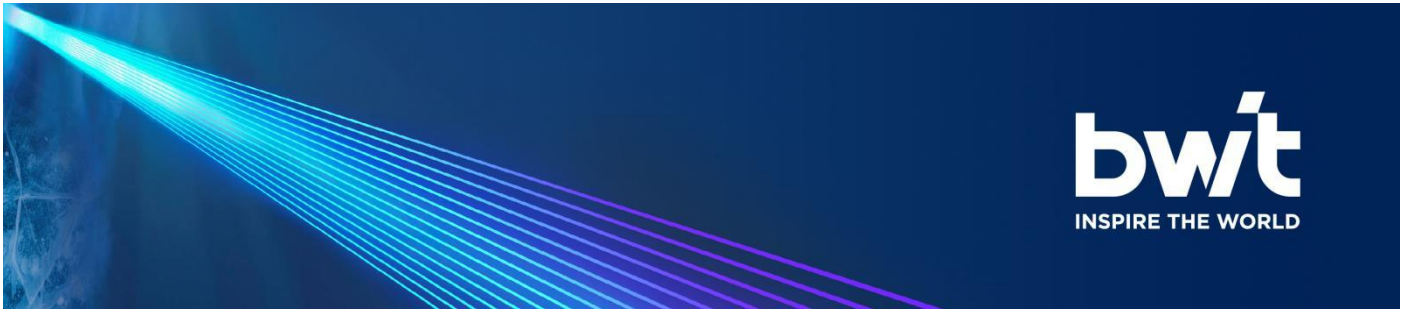

445nm 4W Fiber Coupled Diode Laser

K445H03FN-4.000WN0N-10522

Specifications (25°C)		Symbol	Unit	K445H03FN-4.000WN1N-10522		
				Minimum	Typical	Maximum
Optical Data ⁽¹⁾	CW Output Power	P_O	W	4	-	-
	Center Wavelength	λ_c	nm	445±20		
	Spectral Width (FWHM)	$\Delta\lambda$	nm	-	6	-
	Wavelength Shift with Temperature	$\Delta\lambda/\Delta T$	nm/°C	-	0.1	-
Electrical Data	Electrical-to-Optical Efficiency	PE	%	-	23	-
	Threshold Current	I_{th}	A	-	0.3	-
	Operating Current	I_{op}	A	-	2.8	3.5
	Operating Voltage	V_{op}	V	-	4.5	5
	Slope Efficiency	η	W/A	-	1.4	-
Fiber Data	Core Diameter	D_{core}	μm	-	105	-
	Numeric Aperture	NA	NA	-	0.22	-
	Minimum Bending Radius	-	mm	45	-	-
Others	ESD	V_{esd}	V	-	-	500
	Storage Temperature ⁽²⁾	T_{st}	°C	-20	-	70
	Lead Soldering Temp	T_{ls}	°C	-	-	260
	Lead Soldering Time	t	sec	-	-	10
	Operating Case Temperature ⁽³⁾	T_{op}	°C	15	-	35
	Relative Humidity	RH	%	15	-	75

(1) Data measured under operation output at 4W@25°C.

(2) A non-condensing environment is required for operation and storage.

(3) Operating temperature defined by the package case. Acceptable operating range is 15°C~35°C, but performance may vary.

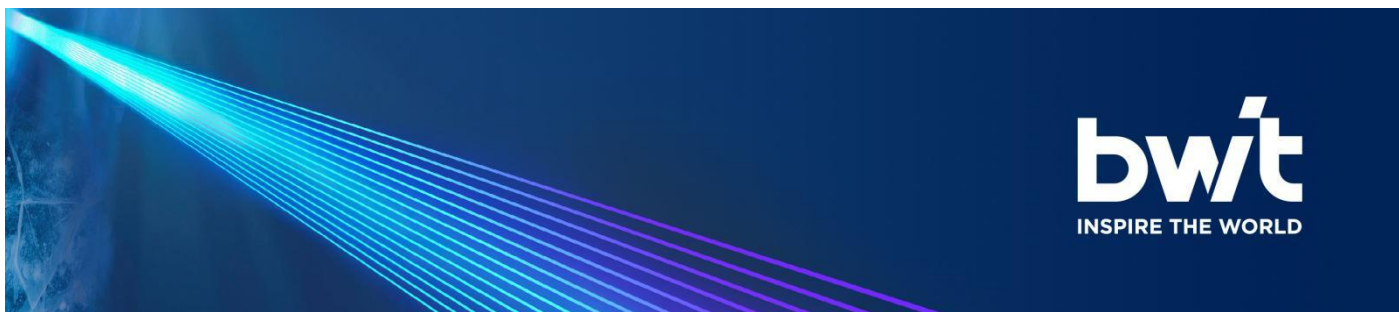

445nm 4W Fiber Coupled Diode Laser

K445H03FN-4.000WN0N-10522

Package Dimensions (mm)

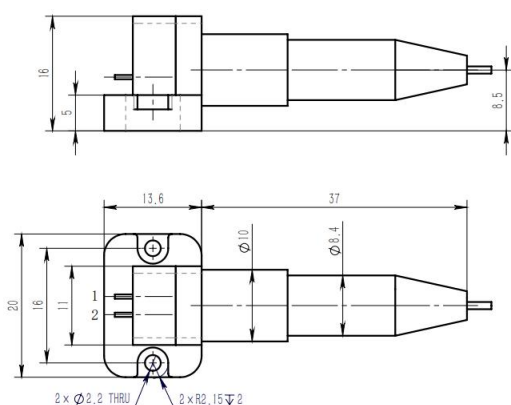

Pin	Function
1	LD(+)
2	LD(-)

OPERATING NOTES

- ◆ Avoid eye and skin exposure to direct radiation during operation.
- ◆ ESD precautions must be taken during transportation, storage, and operation. A short-circuit connection is required between pins during transportation and storage.
- ◆ For lasers with operating currents above 6A, connect leads by soldering. The soldering point should be as close to the middle of the pins as possible, with a temperature below 260°C and a soldering time of less than 10 seconds.
- ◆ Before operating the laser, ensure that the fiber output end is properly cleaned. Follow safety protocols when handling and cutting fiber to avoid injury.
- ◆ Use a constant current power supply and avoid surges during operation.
- ◆ Operate within the rated current and power levels.
- ◆ Ensure proper cooling during operation.
- ◆ The operating temperature range is 15°C to 35°C.
- ◆ The storage temperature range is -20°C to +70°C.



Declaration: information and specifications contained herein are deemed to be reliable and accurate. BWT Beijing reserves the right to change, alter or modify the design and specifications of these products at any time without notice.24-5